

*** Caution: English & Metric Hole Locations are NOT the Same!**

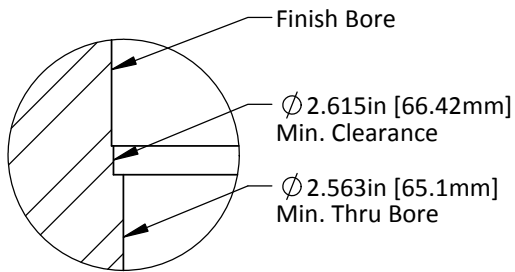

DETAIL SCALE :

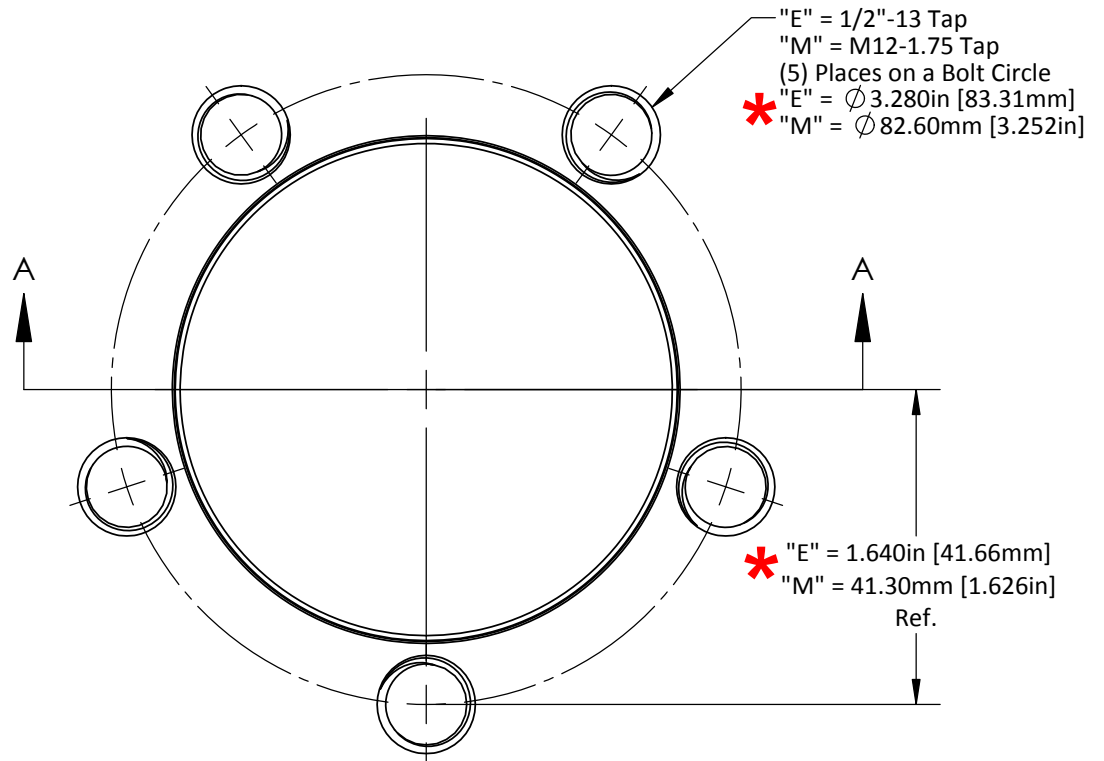
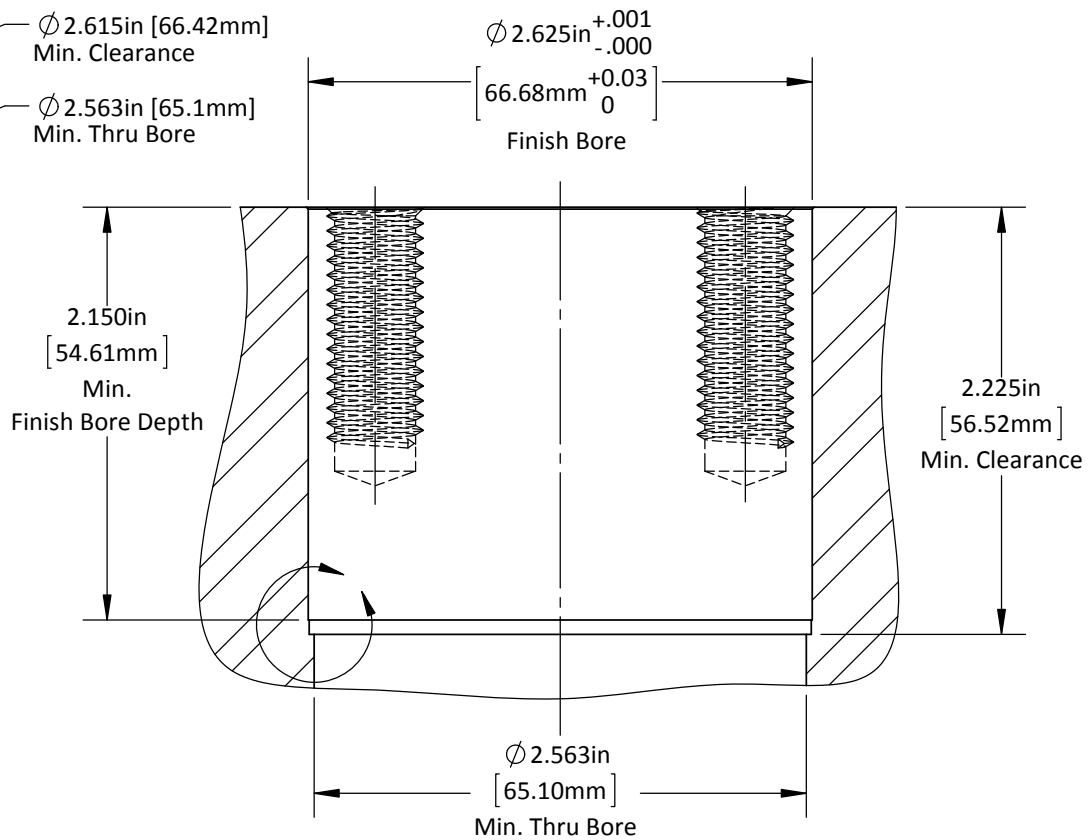

DO NOT SCALE DRAWING

REV 2

This product may be covered by one or more patents or patent applications.
 See <http://www.standardlifters.com/patents.html> for details.

Base-GK200-H3-Machining

STANDARD LIFTERS INC

*** Caution: English & Metric Hole Locations are NOT the Same!**

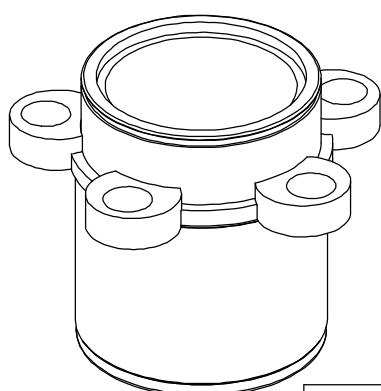
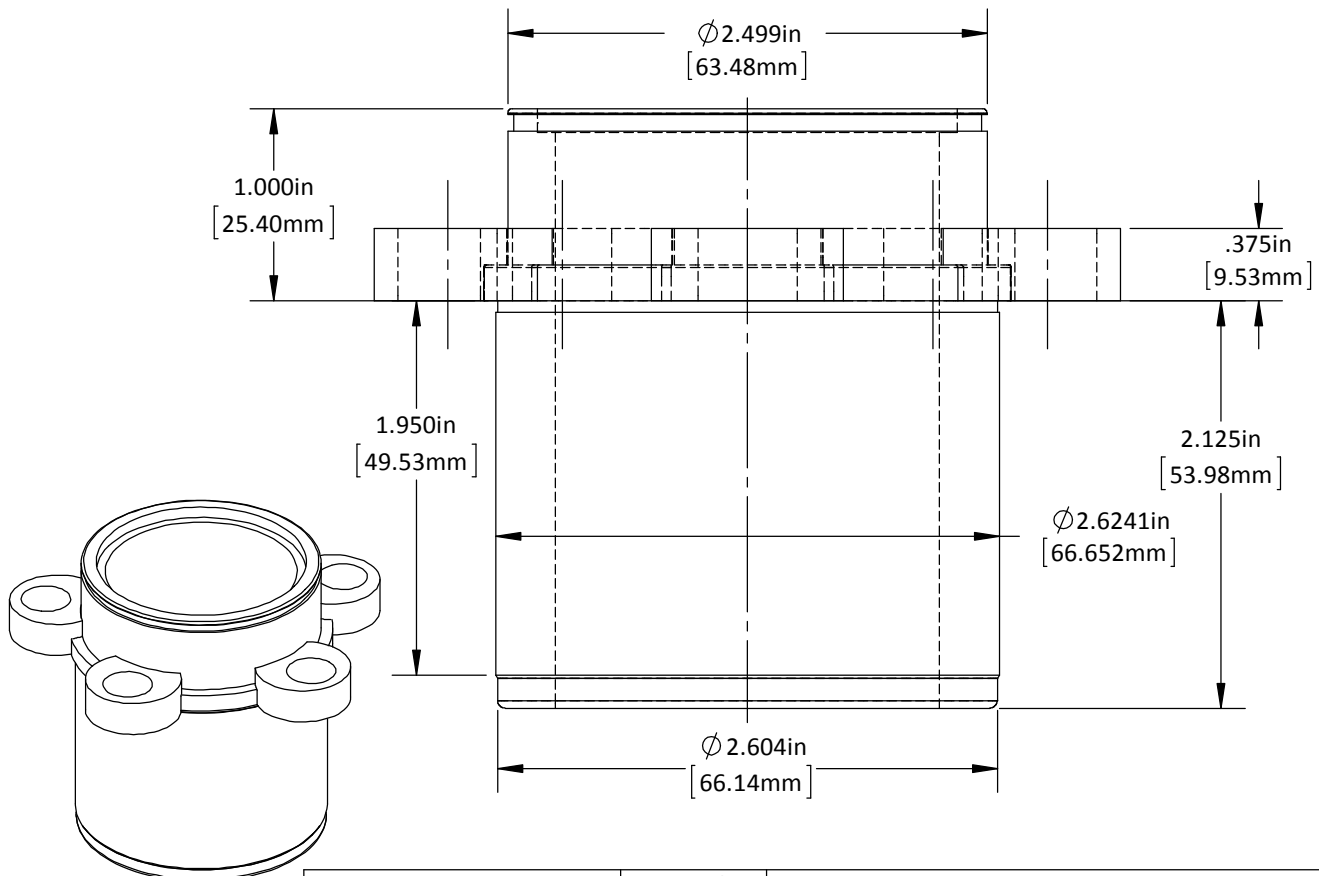
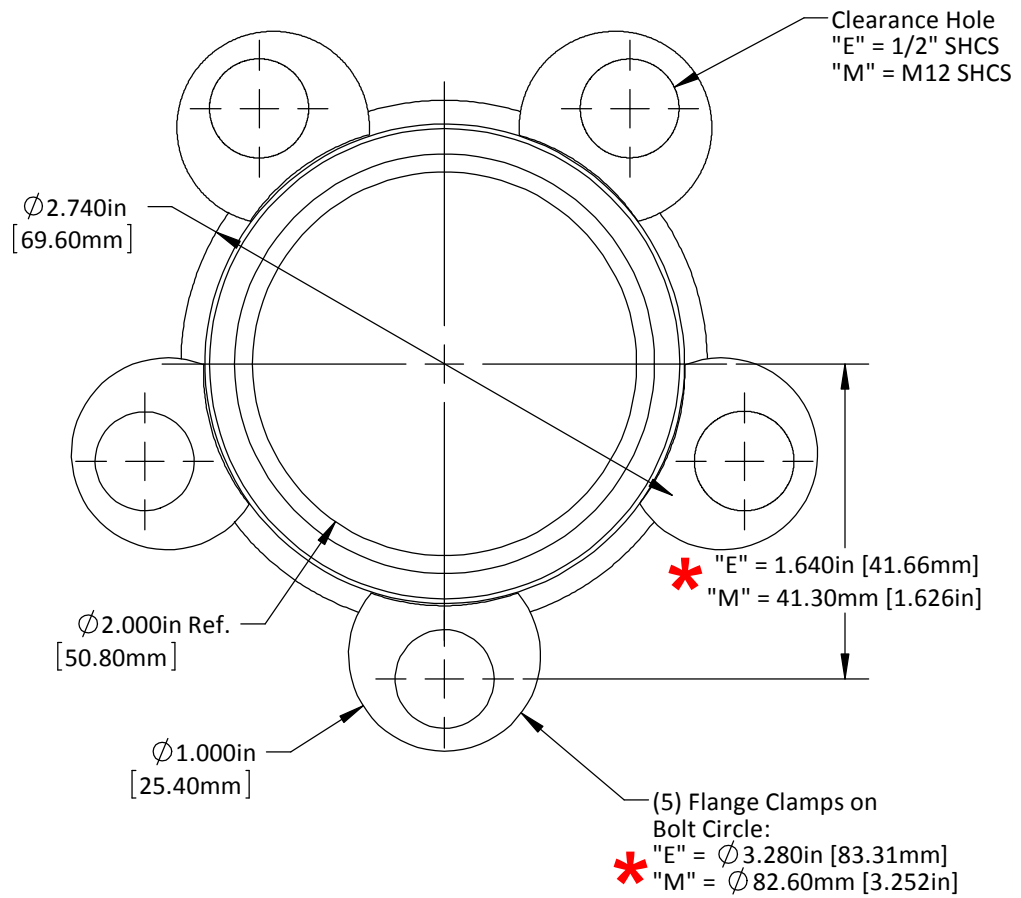

DO NOT SCALE DRAWING | REV 2

This product may be covered by one or more patents or patent applications.
 See <http://www.standardlifters.com/patents.html> for details.

Base-GK200-H3

STANDARD LIFTERS INC