

"E" = 1/2"-13 Tap  
 "M" = M12-1.75 Tap  
 (4) Places

Drill & Ream PF for Dowel  
 "E" =  $\phi$ .500in  
 "M" =  $\phi$ 12.00mm  
 (2) Places

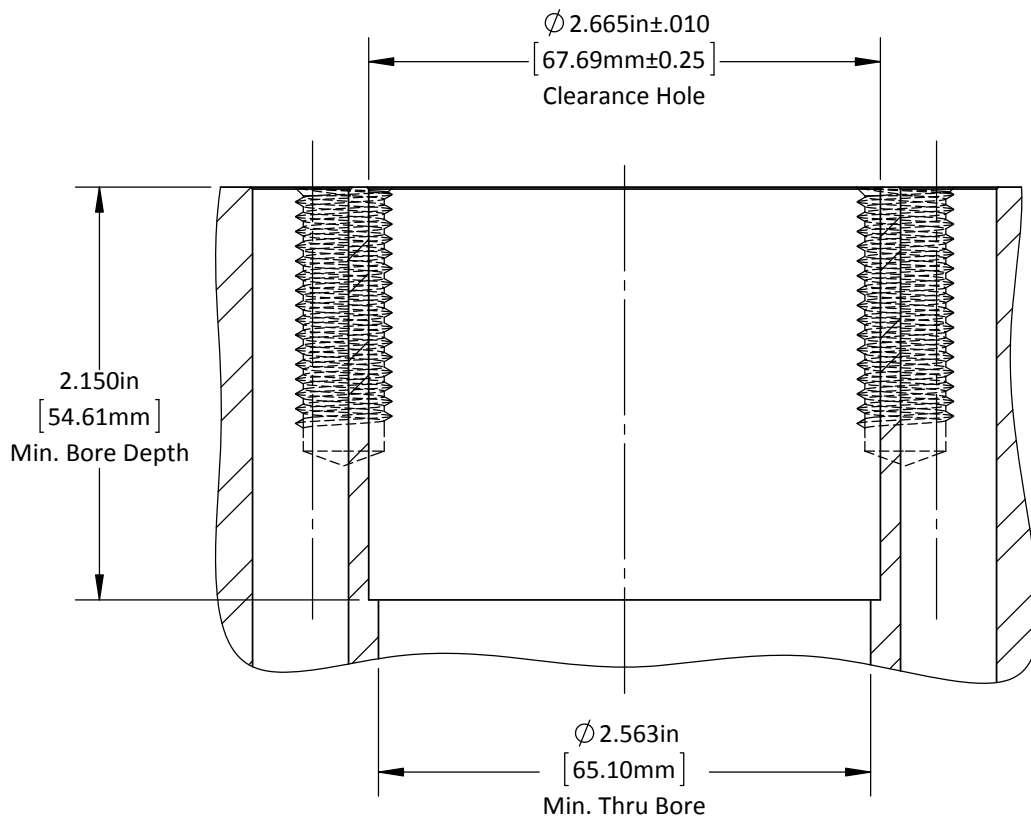

DO NOT SCALE DRAWING	REV 2
This product may be covered by one or more patents or patent applications. See <a href="http://www.standardlifters.com/patents.html">http://www.standardlifters.com/patents.html</a> for details.	

**Base-GK200-D3-Machining**  
**STANDARD LIFTERS INC**

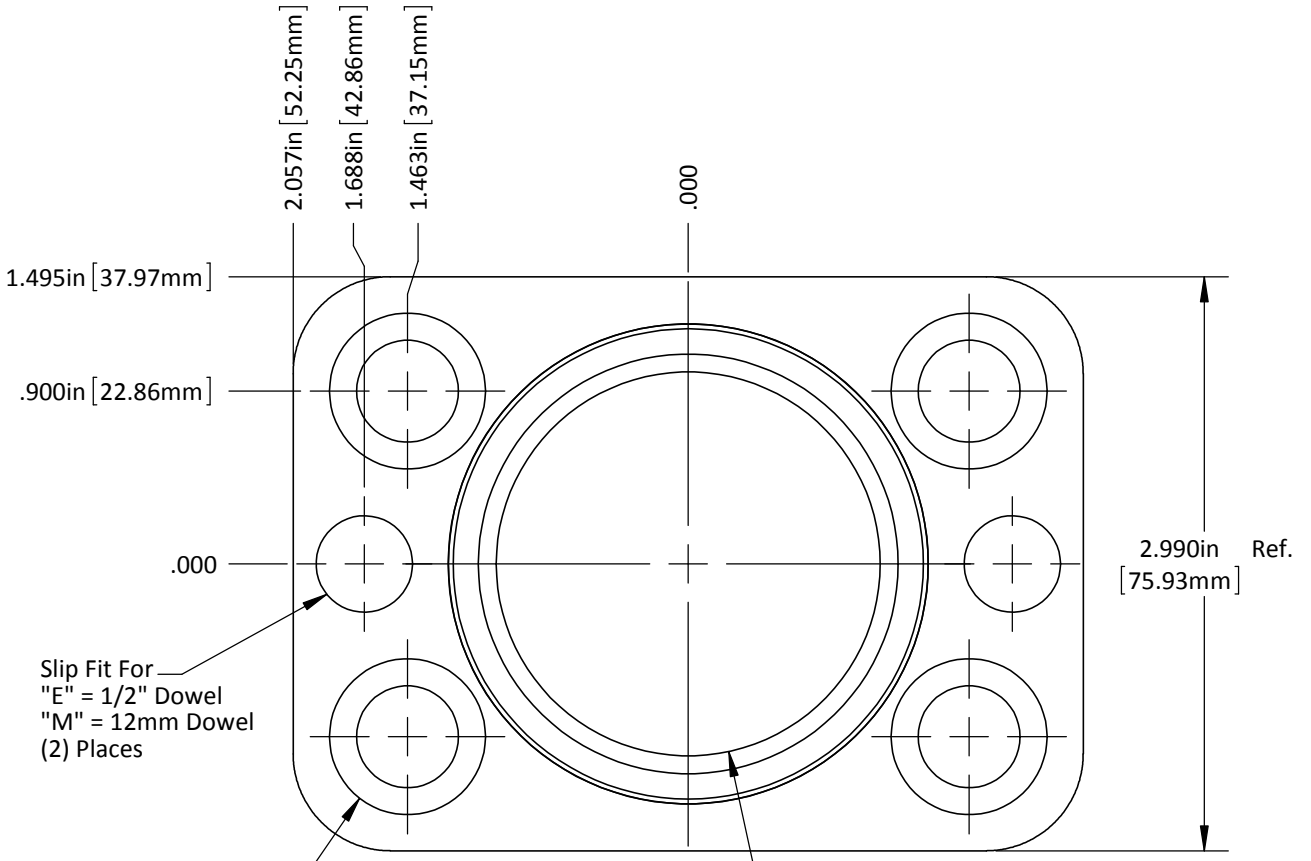

Slip Fit For  
"E" = 1/2" Dowel  
"M" = 12mm Dowel  
(2) Places

Drilled & C'bored For  
"E" = 1/2" SHCS  
"M" = M12 SHCS  
(4) Places

Ø2.000in Ref.  
[50.80mm]

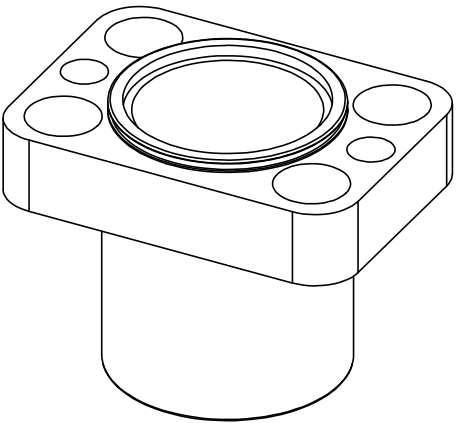
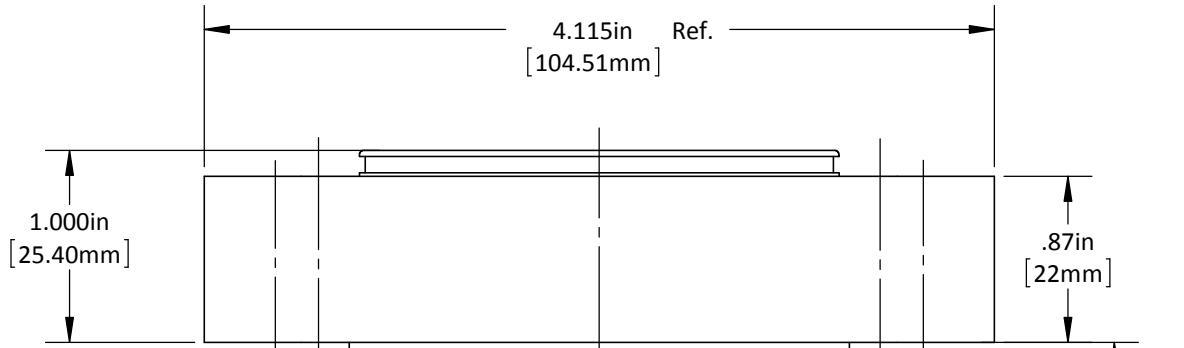

DO NOT SCALE DRAWING | REV 1  
This product may be covered by one or more patents or patent applications.  
See <http://www.standardlifters.com/patents.html> for details.

**Base-GK200-D3**  
**STANDARD LIFTERS INC**