

DO NOT SCALE DRAWING	REV 1
This product may be covered by one or more patents or patent applications. See http://www.standardlifters.com/patents.html for details.	

Base-GK200-A-Machining
STANDARD LIFTERS INC

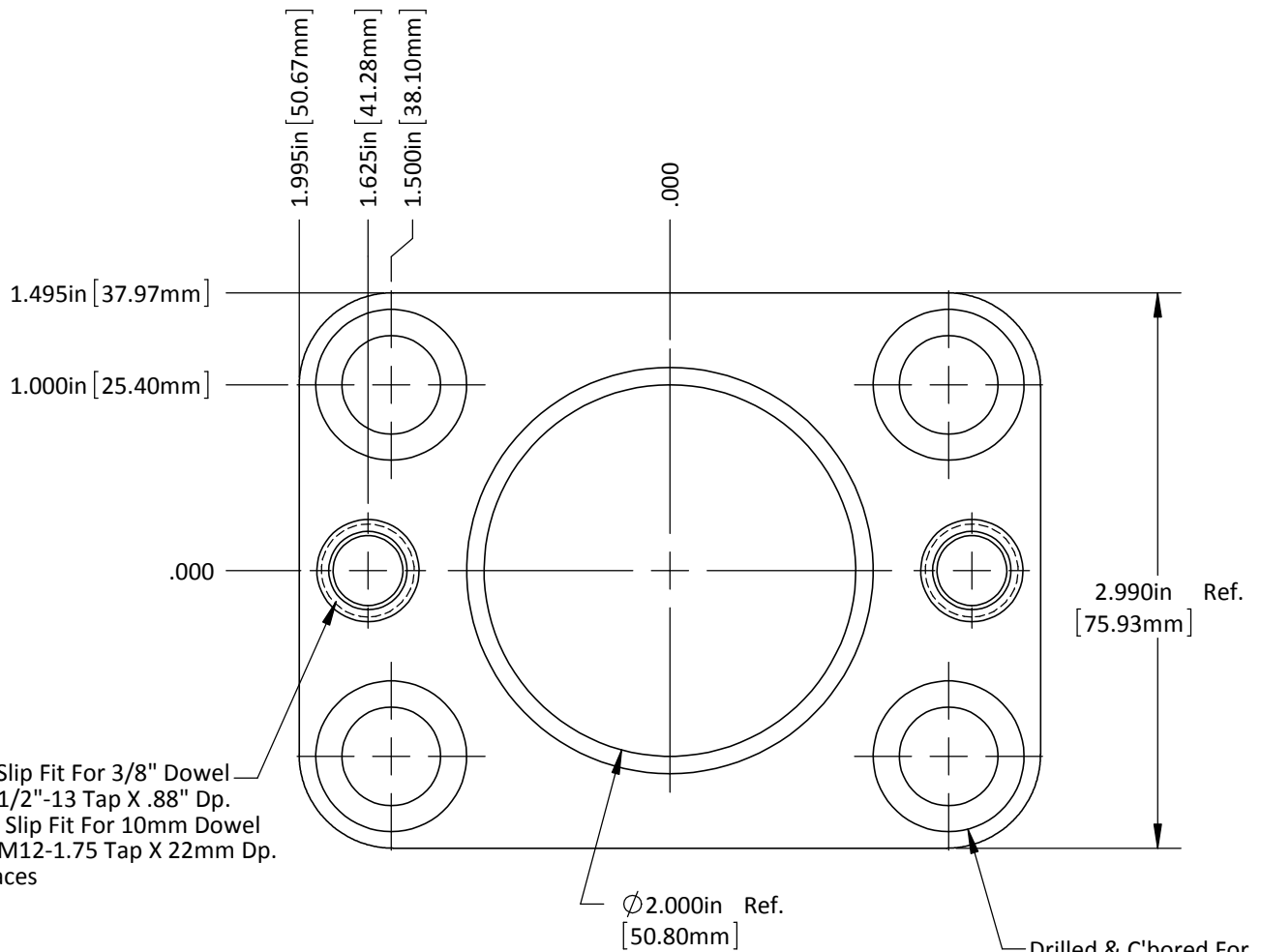

"E" = Slip Fit For 3/8" Dowel
 1/2"-13 Tap X .88" Dp.
 "M" = Slip Fit For 10mm Dowel
 M12-1.75 Tap X 22mm Dp.
 (2) Places

Drilled & C'bored For
 "E" = 1/2" SHCS
 "M" = M12 SHCS
 (4) Places

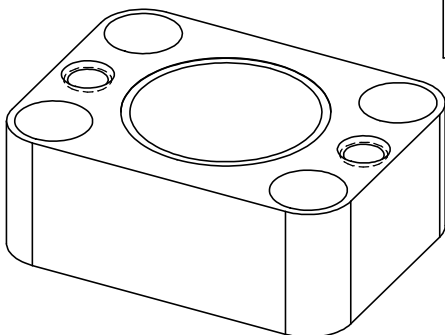
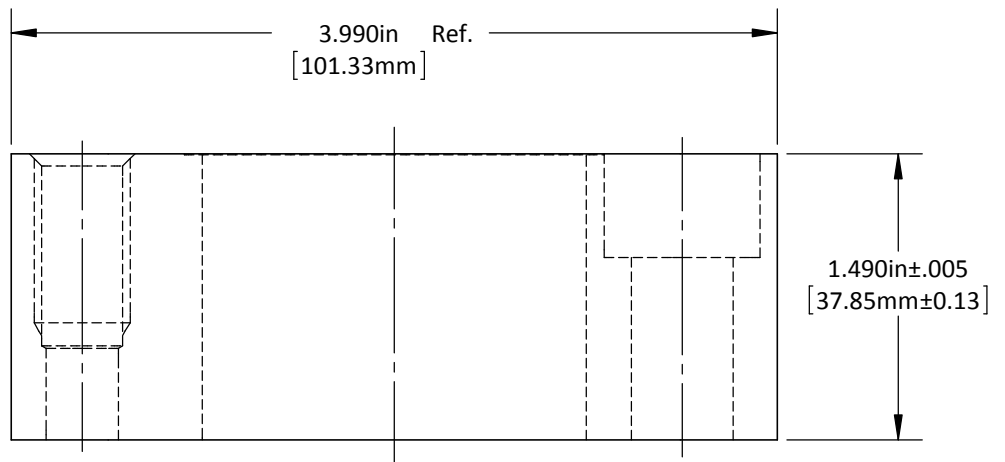

DO NOT SCALE DRAWING REV 1
 This product may be covered by one or more patents or patent applications.
 See <http://www.standardlifters.com/patents.html> for details.

Base-GK200-A
STANDARD LIFTERS INC