

**\*Caution: English & Metric Hole Locations are NOT the Same!**

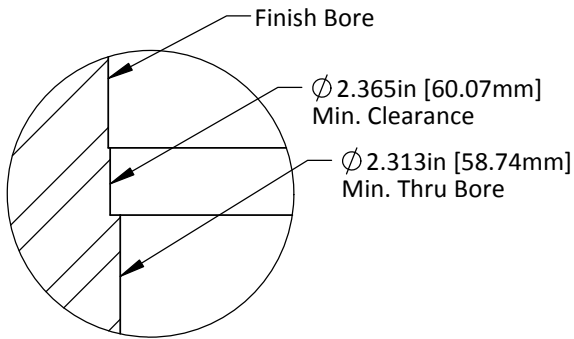

DETAIL B  
 SCALE 2 : 1

.975in  
 [24.77mm]  
 Min.  
 Finish Bore Depth

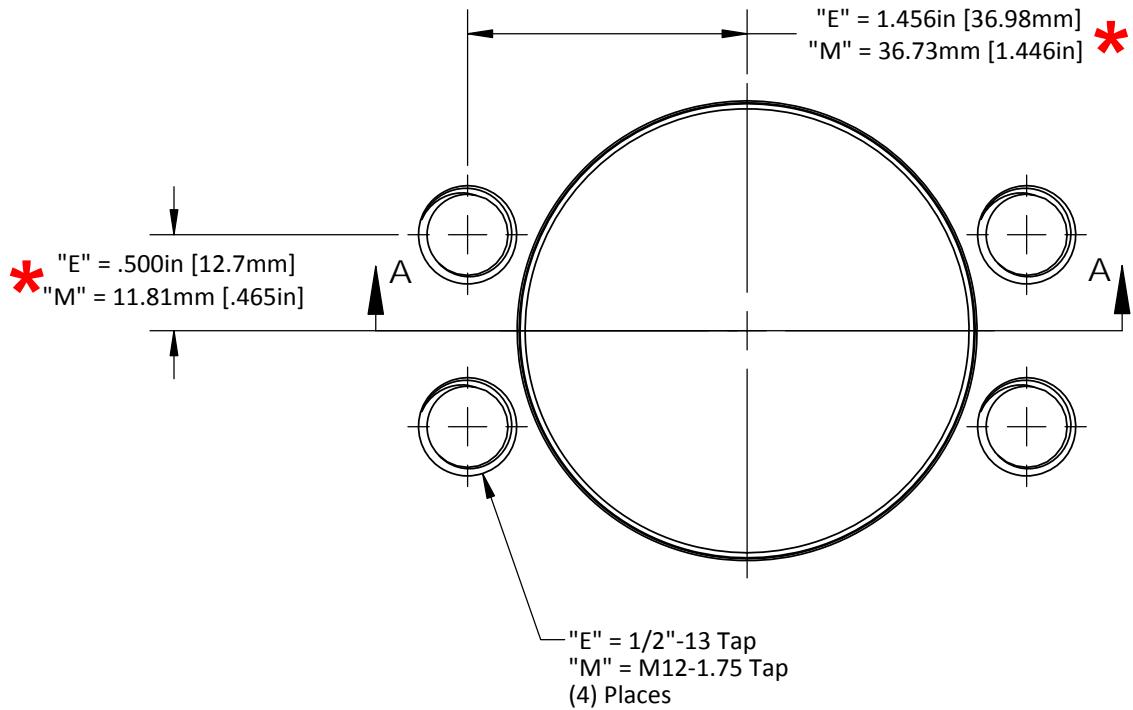
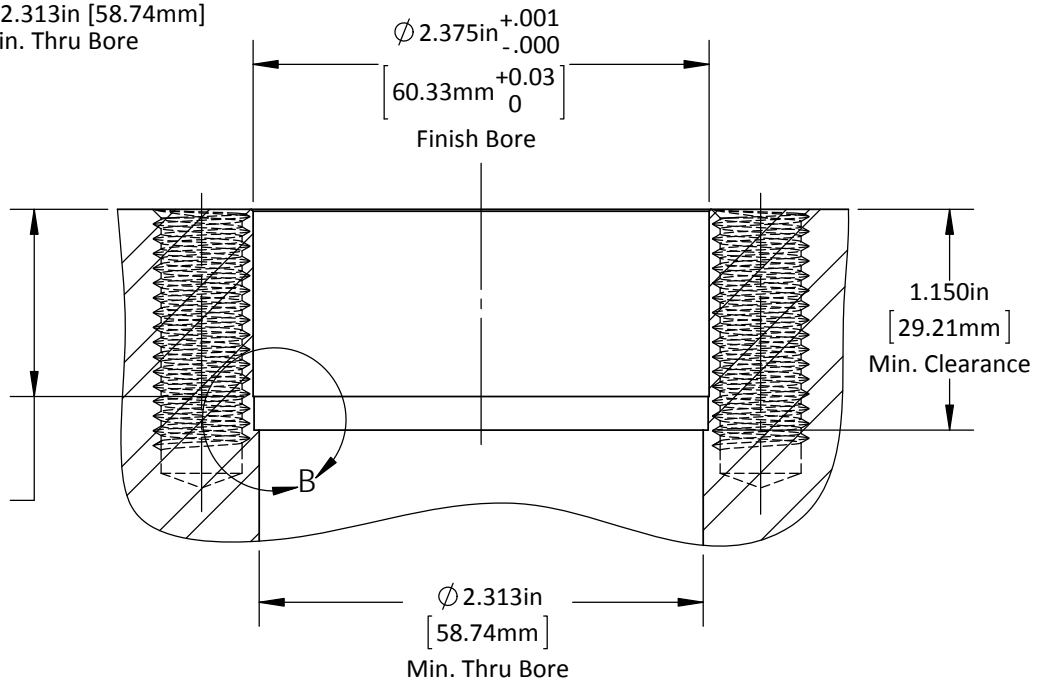

DO NOT SCALE DRAWING

REV 2

This product may be covered by one or more patents or patent applications.  
 See <http://www.standardlifters.com/patents.html> for details.

**GK175-L2-Base Machining**

**STANDARD LIFTERS INC**

**\*Caution: English & Metric Hole Locations are NOT the Same!**

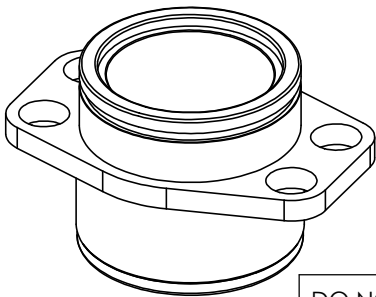
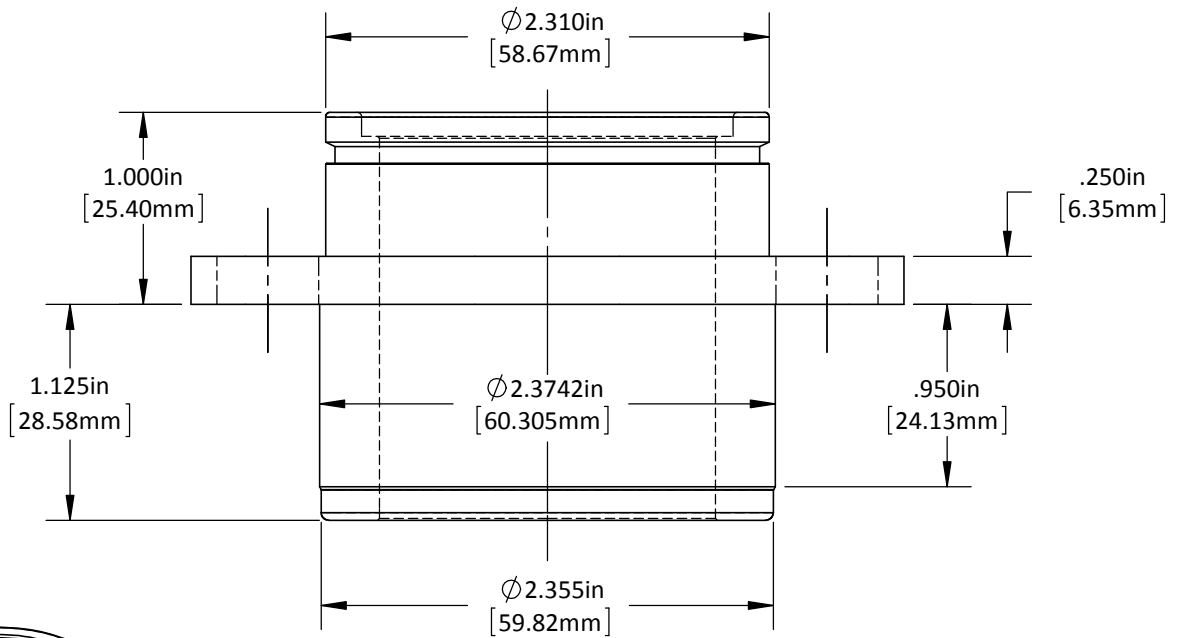
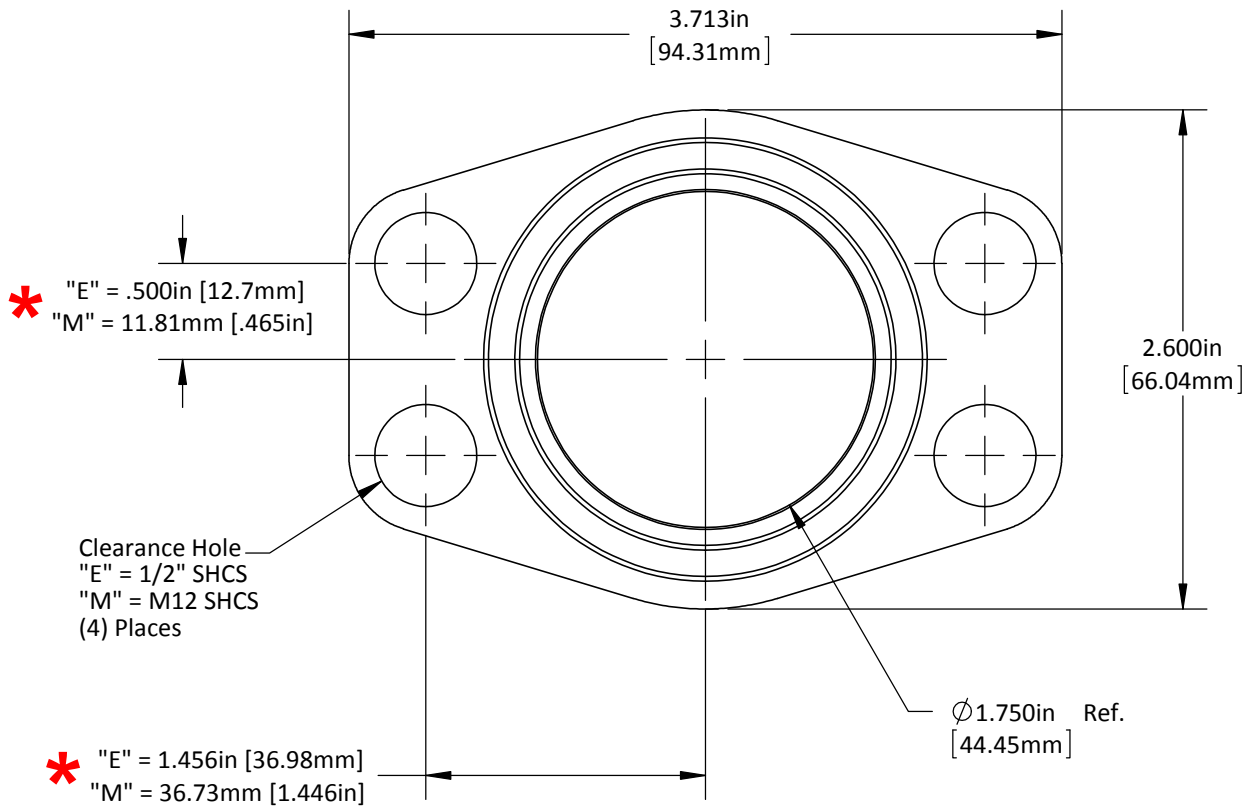

DO NOT SCALE DRAWING

REV 1

This product may be covered by one or more patents or patent applications.  
 See <http://www.standardlifters.com/patents.html> for details.

**Base-GK175-L2**

**STANDARD LIFTERS INC**