

*** Caution: English & Metric Hole Locations are NOT the Same!**

"E" = 1/2"-13 Tap
 "M" = M12-1.75 Tap
 (4) Places on a Bolt Circle
 * "E" = \varnothing 3.020in [76.7mm]
 * "M" = \varnothing 76.00mm [2.992in]

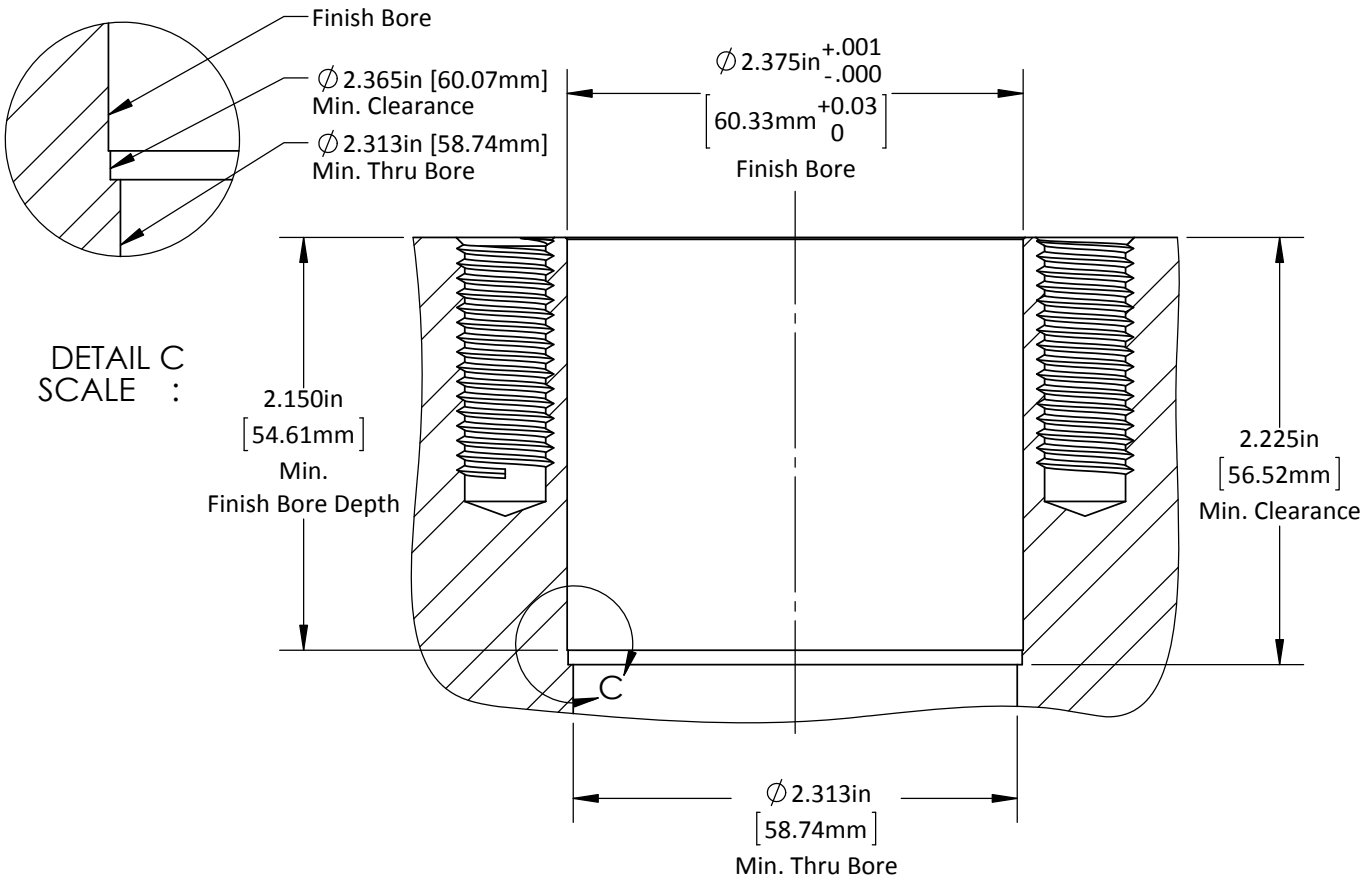

DO NOT SCALE DRAWING	REV 2	GK175-H3-Base Machining STANDARD LIFTERS INC
This product may be covered by one or more patents or patent applications. See http://www.standardlifters.com/patents.html for details.		

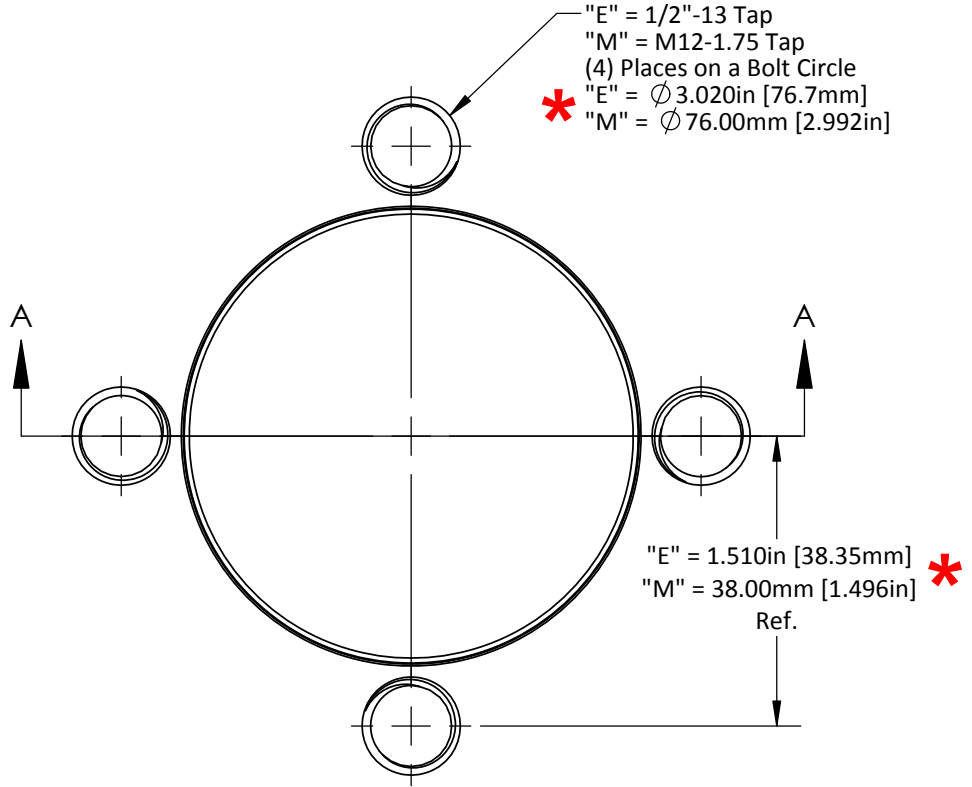
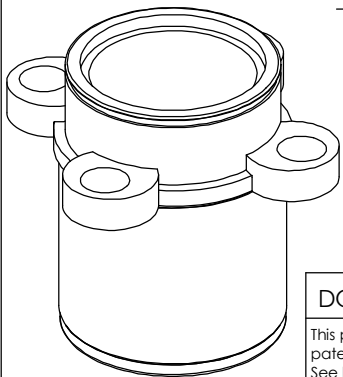
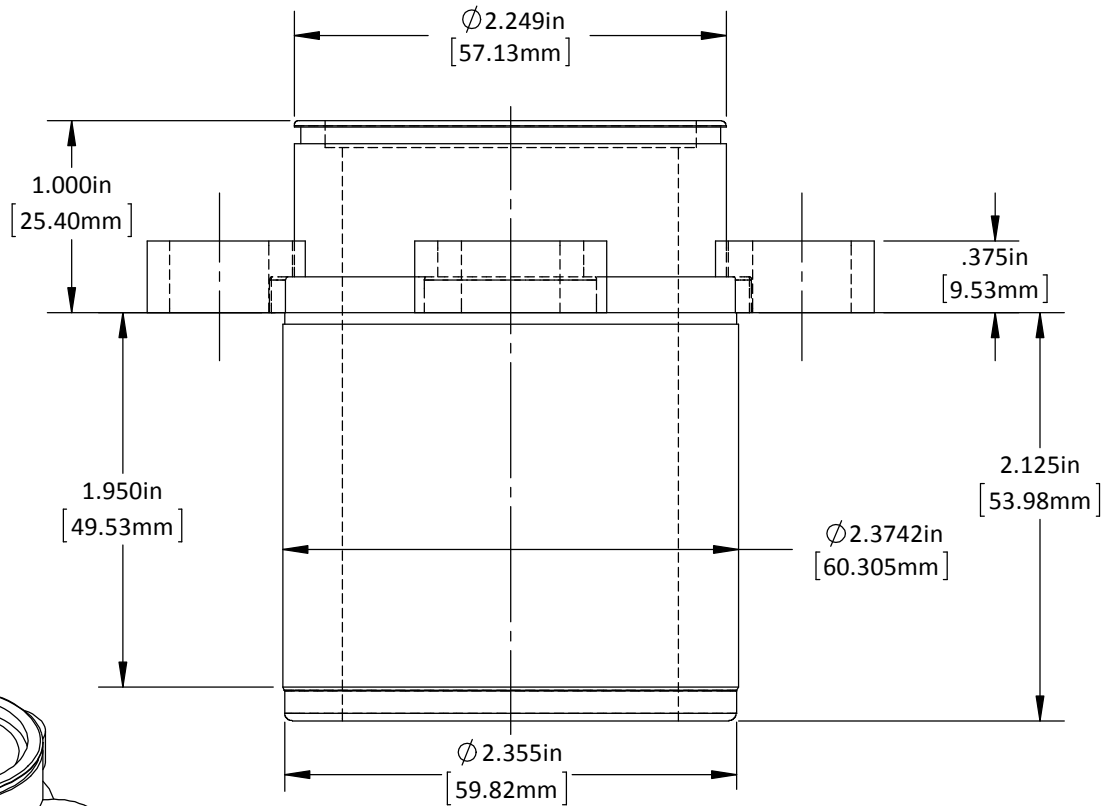
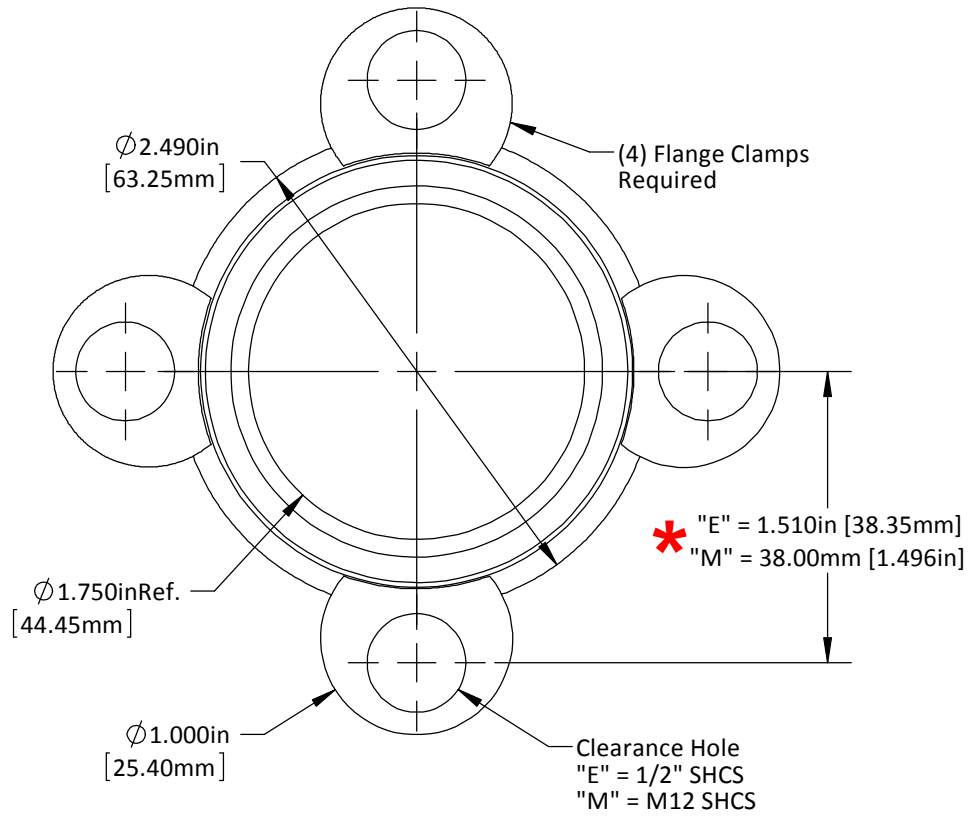

***Caution: English & Metric Hole Locations are NOT the Same!**

DO NOT SCALE DRAWING

REV 2

This product may be covered by one or more patents or patent applications. See <http://www.standardlifters.com/patents.html> for details.

Base-GK175-H3

STANDARD LIFTERS INC