

**\* Caution: English & Metric Hole Locations are NOT the Same!**

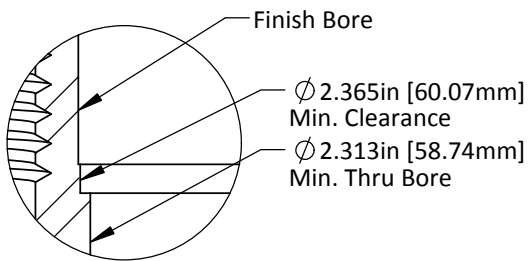

DETAIL SCALE :

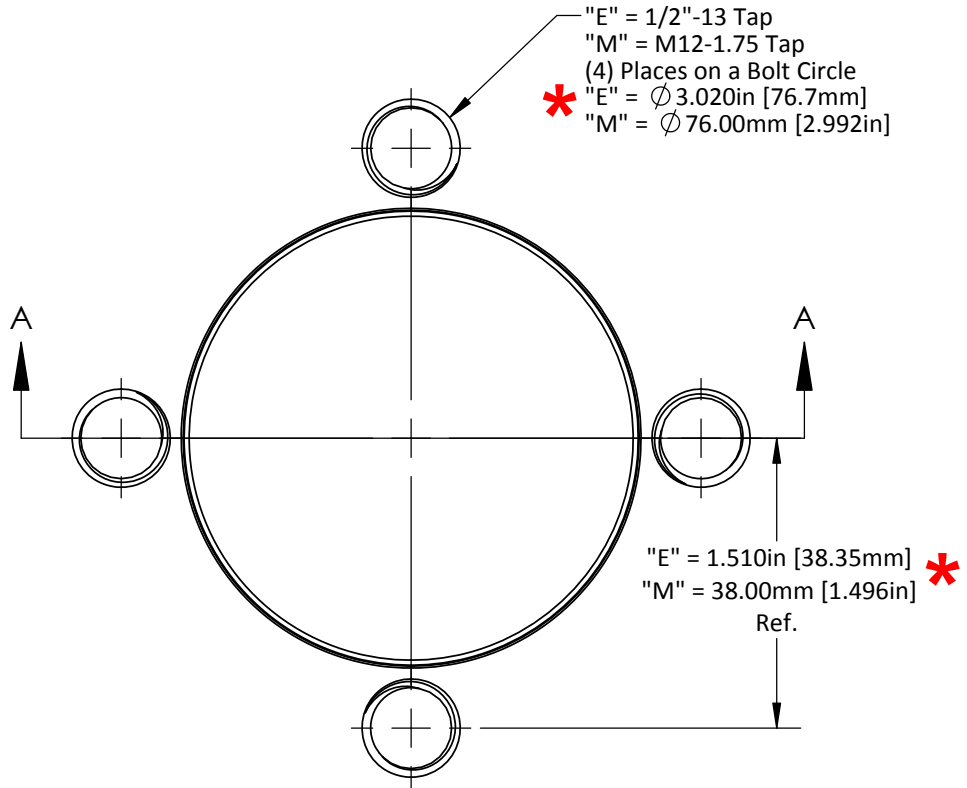
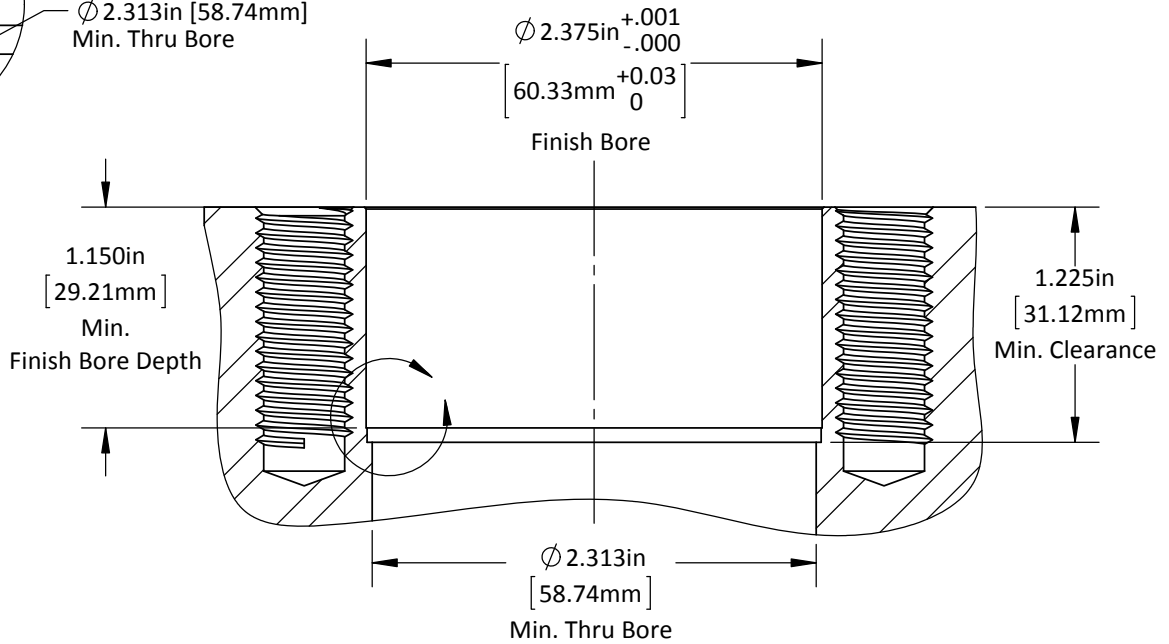

DO NOT SCALE DRAWING

REV 2

This product may be covered by one or more patents or patent applications.  
 See <http://www.standardlifters.com/patents.html> for details.

**GK175-H2-Base Machining**

**STANDARD LIFTERS INC**

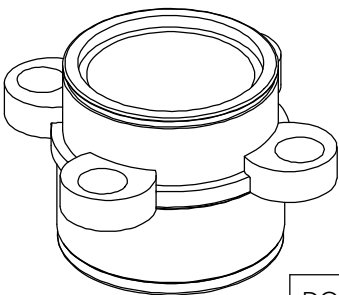
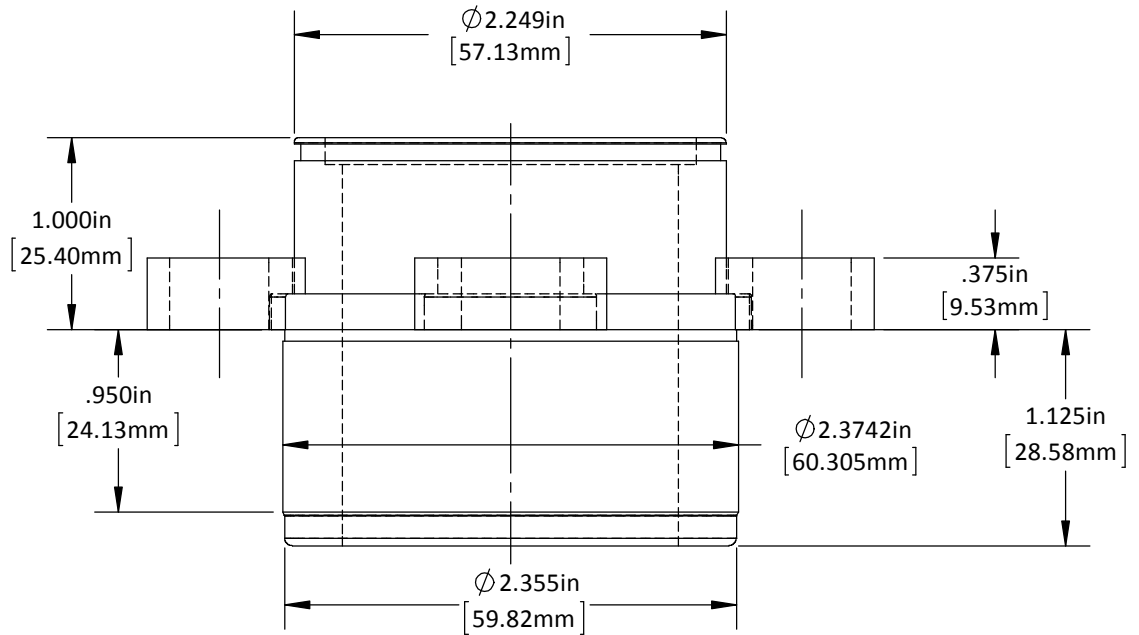
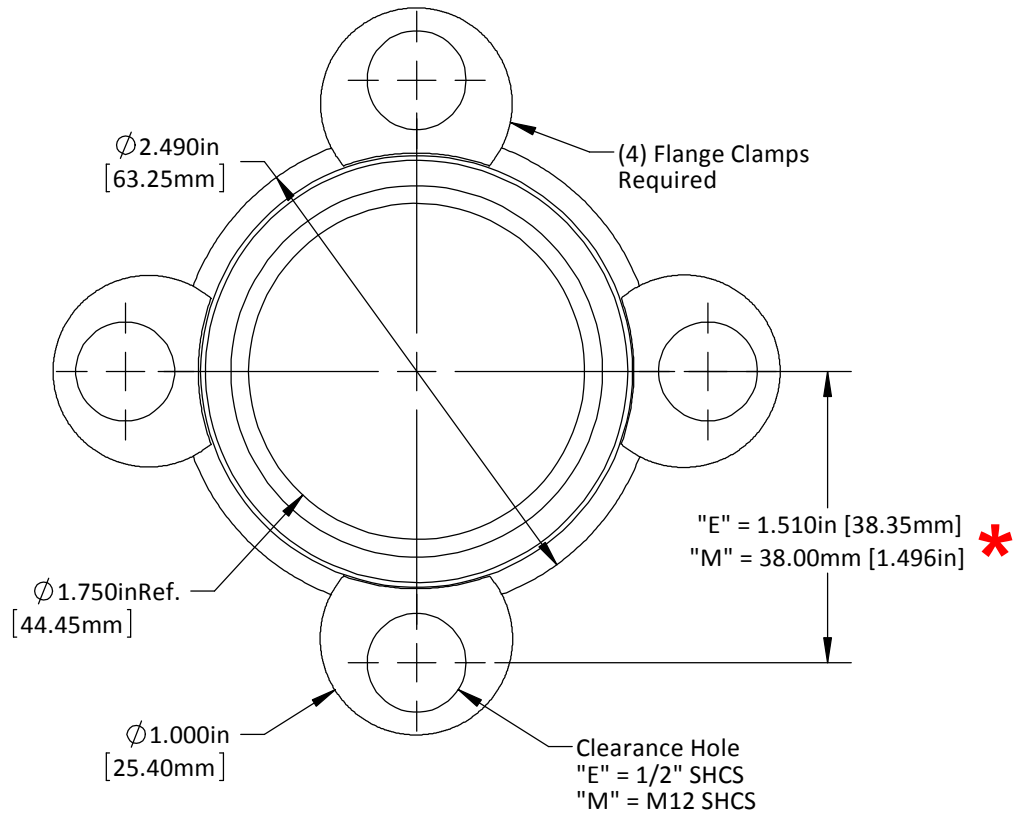

**\* Caution: English & Metric Hole Locations are NOT the Same!**

DO NOT SCALE DRAWING	REV 2	<b>Base-GK175-H2</b> <b>STANDARD LIFTERS INC</b>
This product may be covered by one or more patents or patent applications. See <a href="http://www.standardlifters.com/patents.html">http://www.standardlifters.com/patents.html</a> for details.		