

*** Caution: English & Metric Hole Locations are NOT the Same!**

"E" = 1/2"-13 Tap
 "M" = M12-1.75 Tap
 (3) Places on a Bolt Circle
 * "E" = \varnothing 2.774in [70.46mm]
 "M" = \varnothing 70.46mm [2.774in]

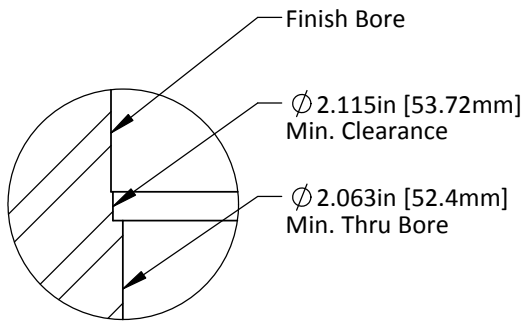

DETAIL C
 SCALE :

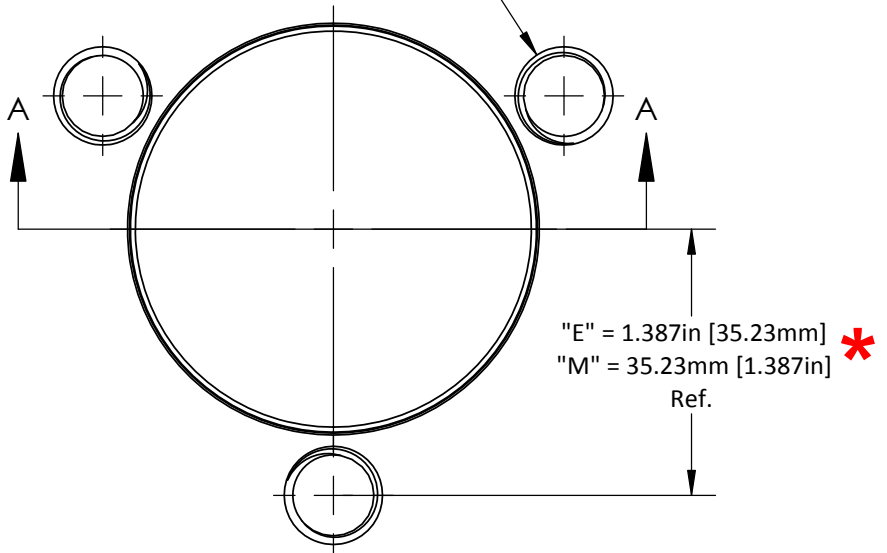
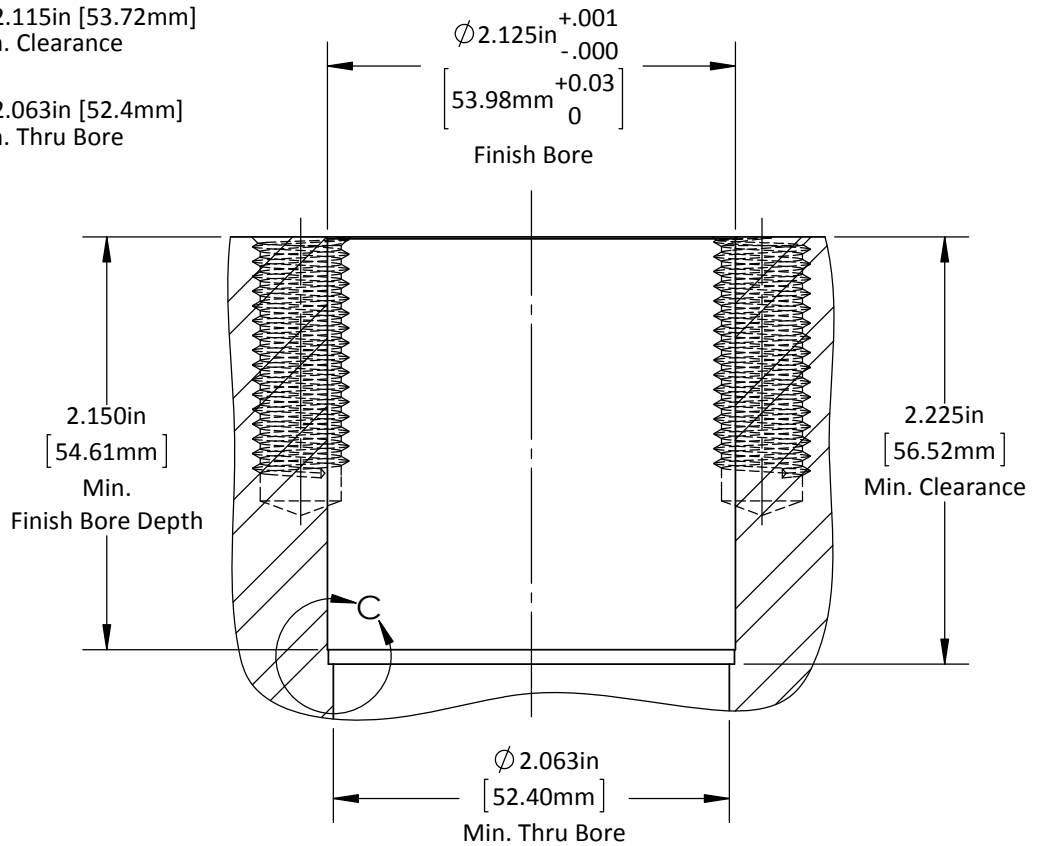

DO NOT SCALE DRAWING	REV 2	GK150-H3-Base Machining
This product may be covered by one or more patents or patent applications. See http://www.standardlifters.com/patents.html for details.		

*** Caution: English & Metric Hole Locations are NOT the Same!**

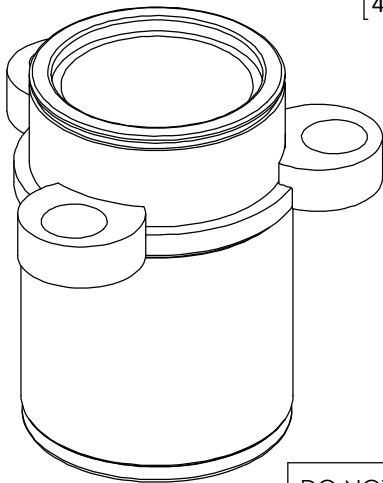
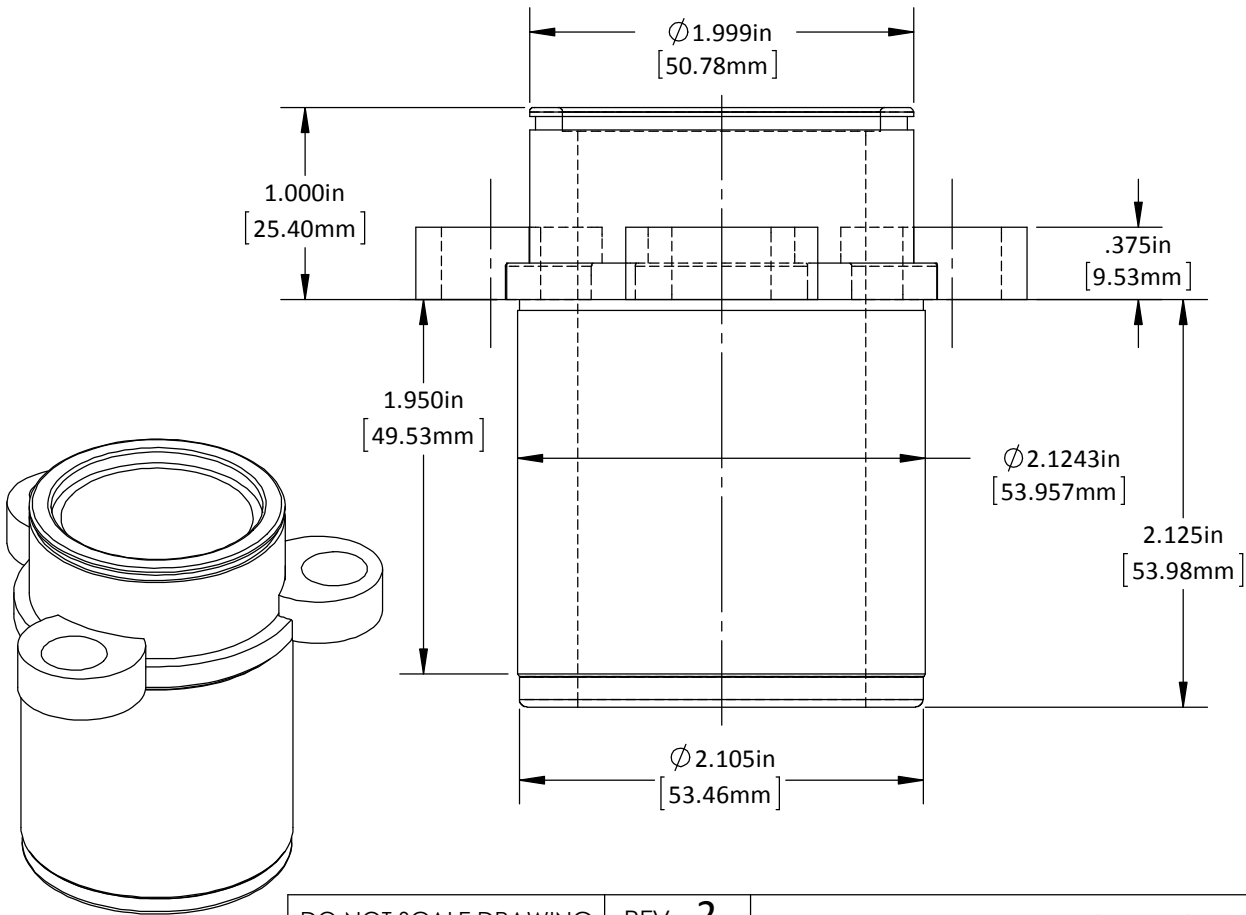
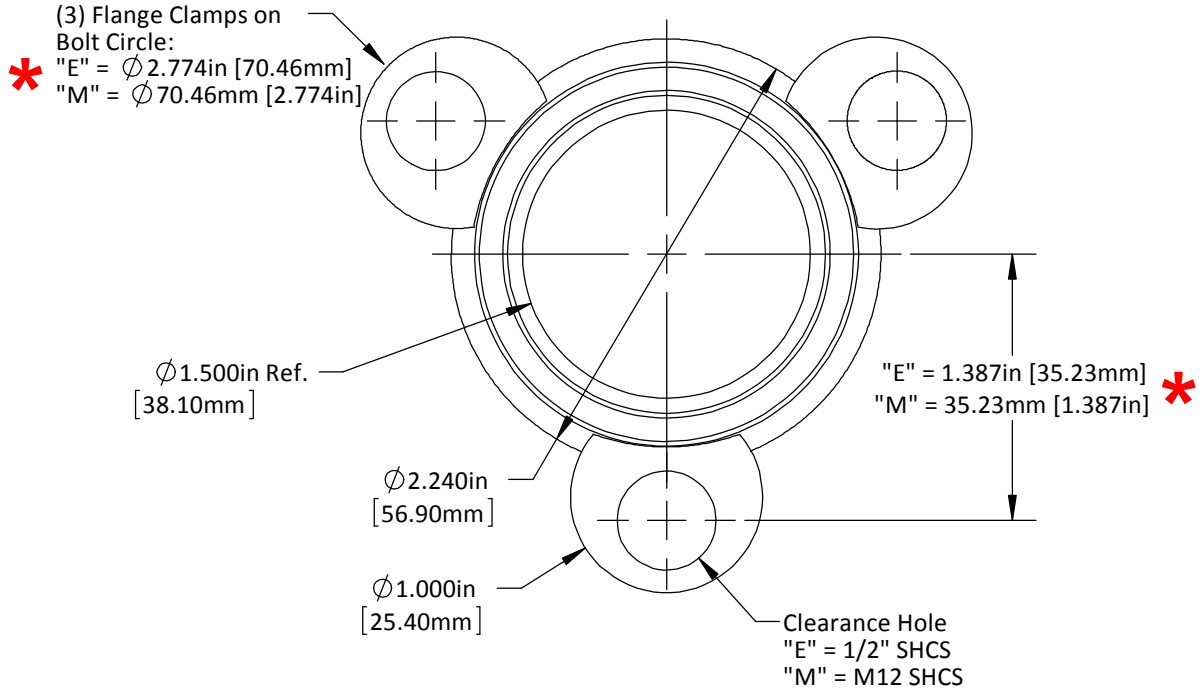

DO NOT SCALE DRAWING REV 2

This product may be covered by one or more patents or patent applications.
 See <http://www.standardlifters.com/patents.html> for details.

Base-GK150-H3

STANDARD LIFTERS INC