

DO NOT SCALE DRAWING

REV 2

This product may be covered by one or more patents or patent applications.  
See <http://www.standardlifters.com/patents.html> for details.

**GK120-D2-Base Machining**

**STANDARD LIFTERS INC**

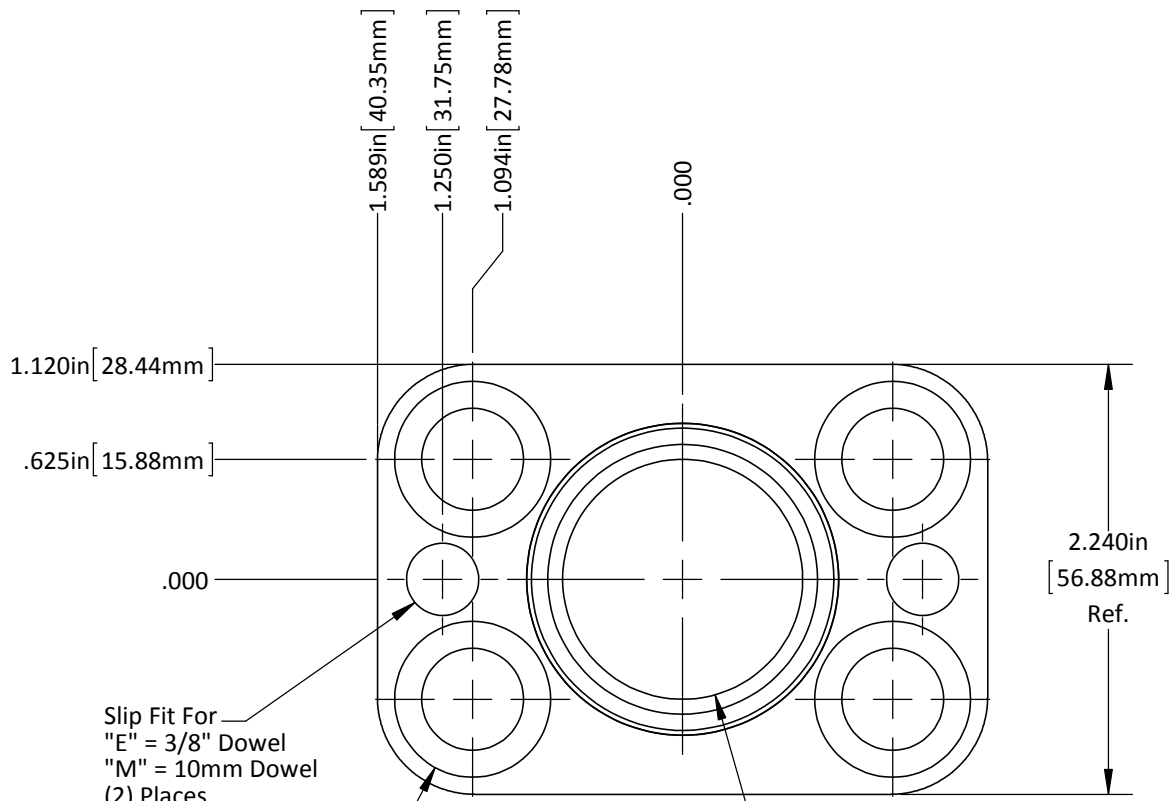

Slip Fit For  
 "E" = 3/8" Dowel  
 "M" = 10mm Dowel  
 (2) Places

Drilled & C'bored For  
 "E" = 1/2" SHCS  
 "M" = M12 SHCS  
 (4) Places

Ø 1.250in Ref.  
 [31.75mm]

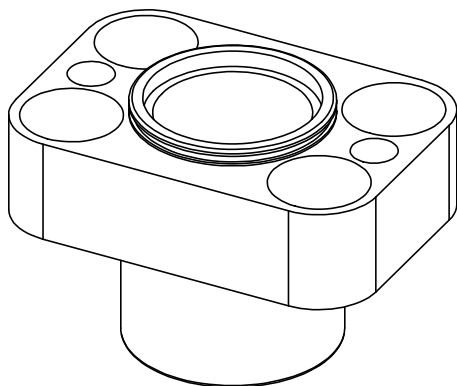
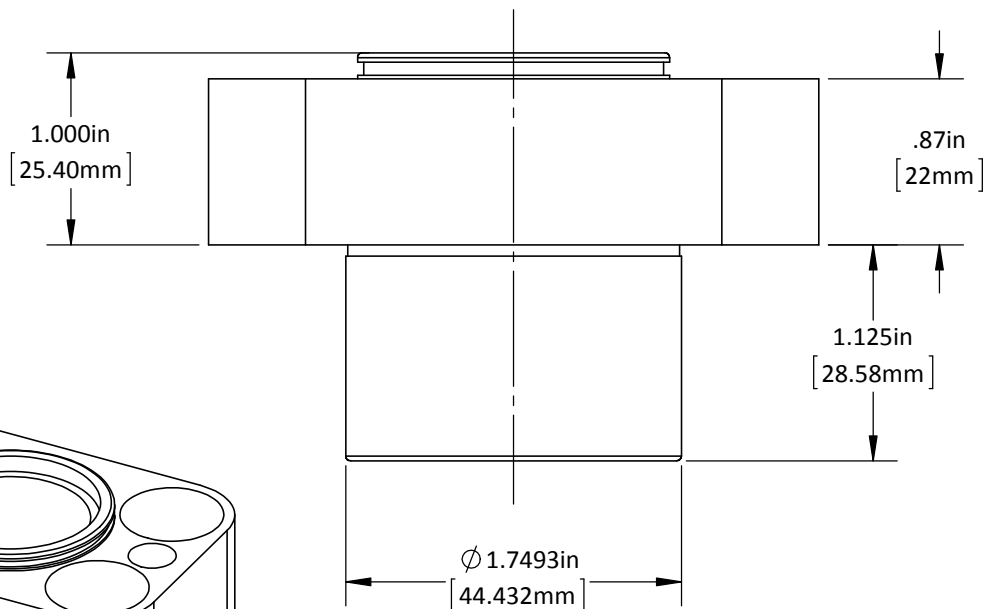

DO NOT SCALE DRAWING | REV 1  
 This product may be covered by one or more patents or patent applications.  
 See <http://www.standardlifters.com/patents.html> for details.

**Base-GK120-D2**  
**STANDARD LIFTERS INC**