

DO NOT SCALE DRAWING    REV 1

This product may be covered by one or more patents or patent applications.  
 See <http://www.standardlifters.com/patents.html> for details.

**GK120-B-Base Machining**

**STANDARD LIFTERS INC**

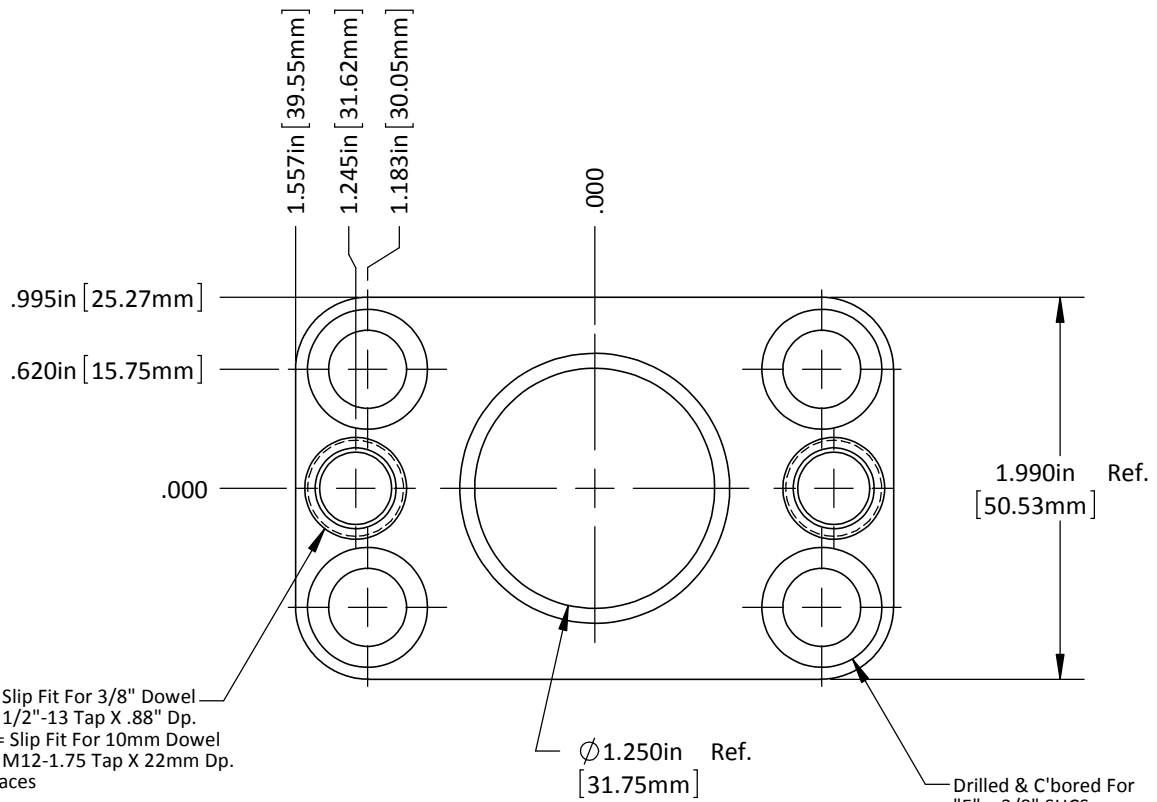

"E" = Slip Fit For 3/8" Dowel  
1/2"-13 Tap X .88" Dp.  
"M" = Slip Fit For 10mm Dowel  
M12-1.75 Tap X 22mm Dp.  
(2) Places

Ø1.250in Ref.  
[31.75mm]

Drilled & C'bored For  
"E" = 3/8" SHCS  
"M" = M10 SHCS  
(4) Places

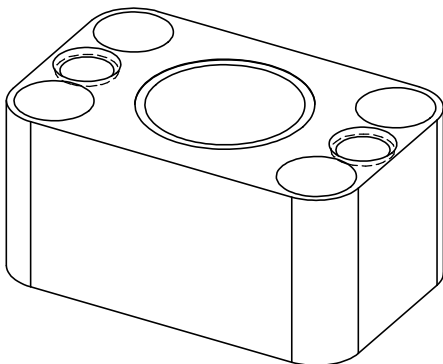
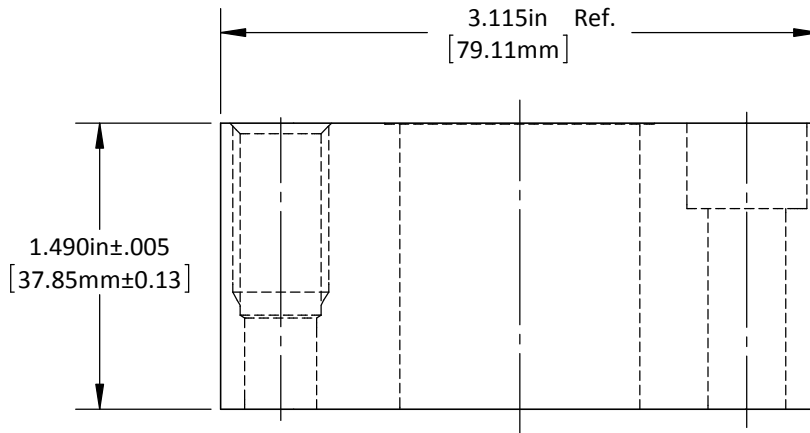

DO NOT SCALE DRAWING

REV 1

This product may be covered by one or more patents or patent applications.  
See <http://www.standardlifters.com/patents.html> for details.

**Base-GK120-B**

**STANDARD LIFTERS INC**