

DO NOT SCALE DRAWING

REV 1

This product may be covered by one or more patents or
 patent applications.
 See <http://www.standardlifters.com/patents.html> for details.

GK120-A-Base Machining

STANDARD LIFTERS INC

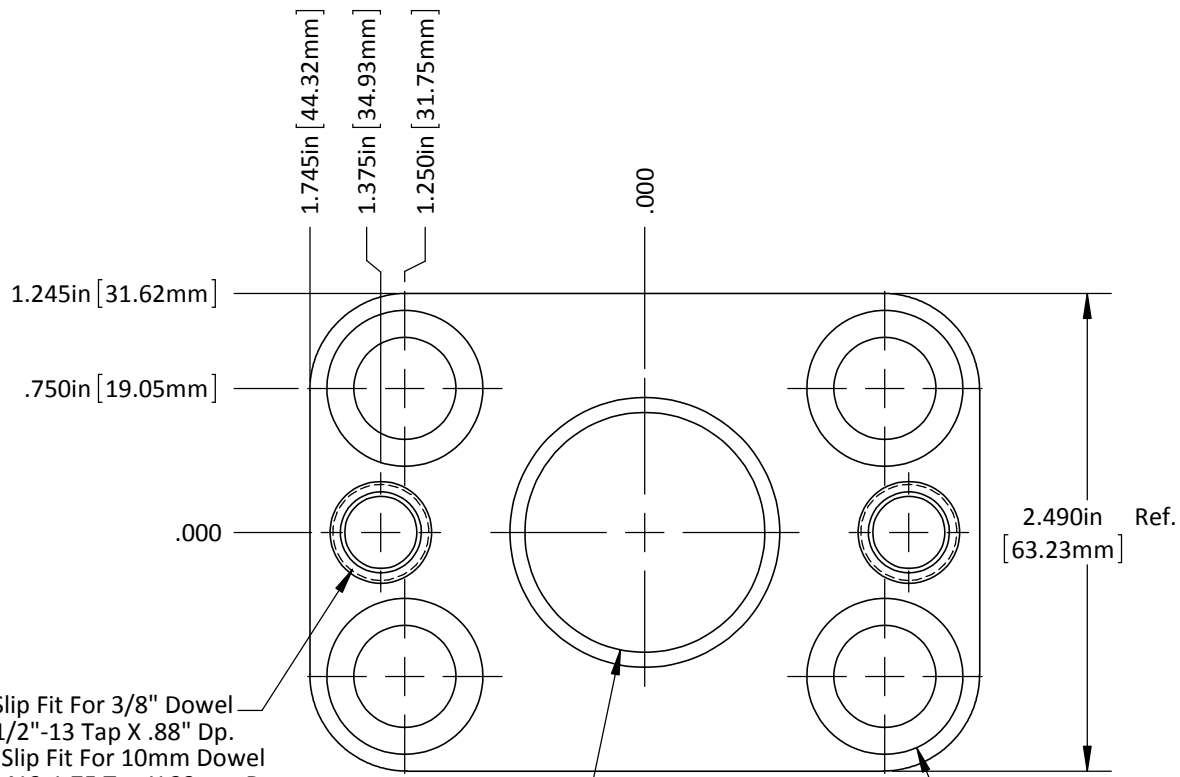

"E" = Slip Fit For 3/8" Dowel
 1/2"-13 Tap X .88" Dp.
 "M" = Slip Fit For 10mm Dowel
 M12-1.75 Tap X 22mm Dp.
 (2) Places

$\varnothing 1.250$ in Ref.
 [31.75mm]

Drilled & C'bored For
 "E" = 1/2" SHCS
 "M" = M12 SHCS
 (4) Places

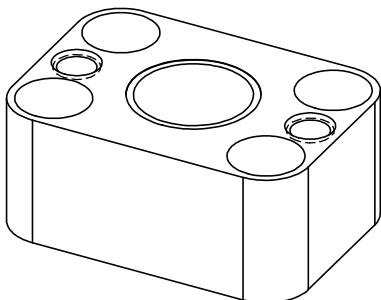
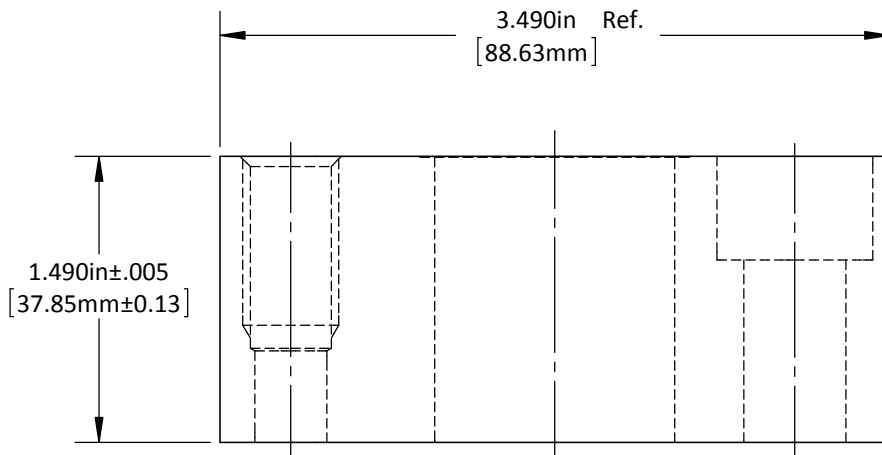

DO NOT SCALE DRAWING REV 1
 This product may be covered by one or more patents or patent applications.
 See <http://www.standardlifters.com/patents.html> for details.

Base-GK120-A
STANDARD LIFTERS INC