

STANDARD LIFTERS

MAKING INNOVATION THE STANDARD



“J” Style Base - New Lifter System

Guided Keeper + Modular Spring Retainer = ALL IN ONE

New

Available in 51 heights every .125" increment

Machining done in one setup from the top

2 Cap Screws (provide redundancy, anti-rotation, and strength)

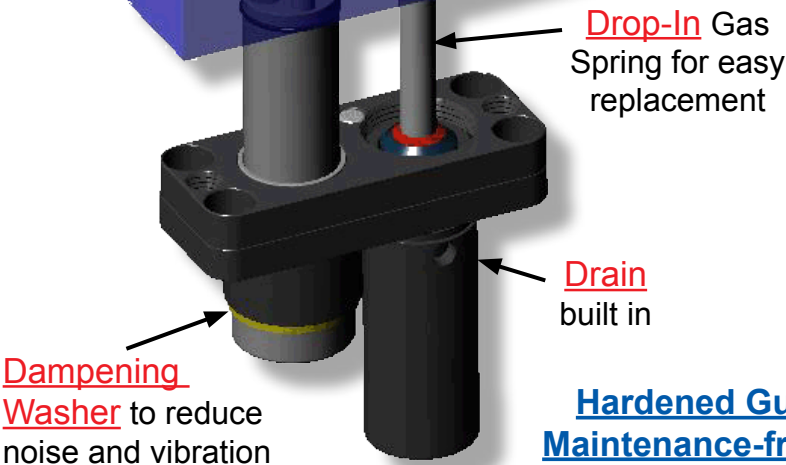

Drop-In Gas Spring for easy replacement

Drain built in

Threaded Spring Can for height adjustment

Locking Dowel creates a semipermanent assembly

Dampening Washer to reduce noise and vibration

Hardened Guide Pin & Maintenance-free Bushing

GK120-J1 Series - System Cost: \$498

\$145(starting price) + \$0.75 per .125" of Guide Pin + \$0.50 per .5" of Spring Pocket (depth of hole) = \$186 + \$62 Drop in Gas Spring (est.)

Investigate your other options ... design, cost, and labor

“All in one” Stock Lifters

- Unit = \$315 (gas spring internal)

Cost: \$630

Pins, Bushings, Spools

- Guide Pins = \$110
 - Bushings = \$105
 - Spools = \$45
 - Gas Springs = \$124
 - Steel and Machining needed to Retain Gas Spring = \$150
- Cost: \$534

Footed Keepers

Not even worth looking at ... when you consider the cost of Steel, Machining, Heat Treat, Grinding, Setting, etc. ... the costs are out of this world.