

STANDARD LIFTERS

MAKING INNOVATION THE STANDARD



Toll Free: 1-877-754-3837 ~ Fax: (616) 301-2182 ~ www.standardlifters.com ~ sales@standardlifters.com

GK175 Specifications

GK175-H2 & H3 Base (Bushing)

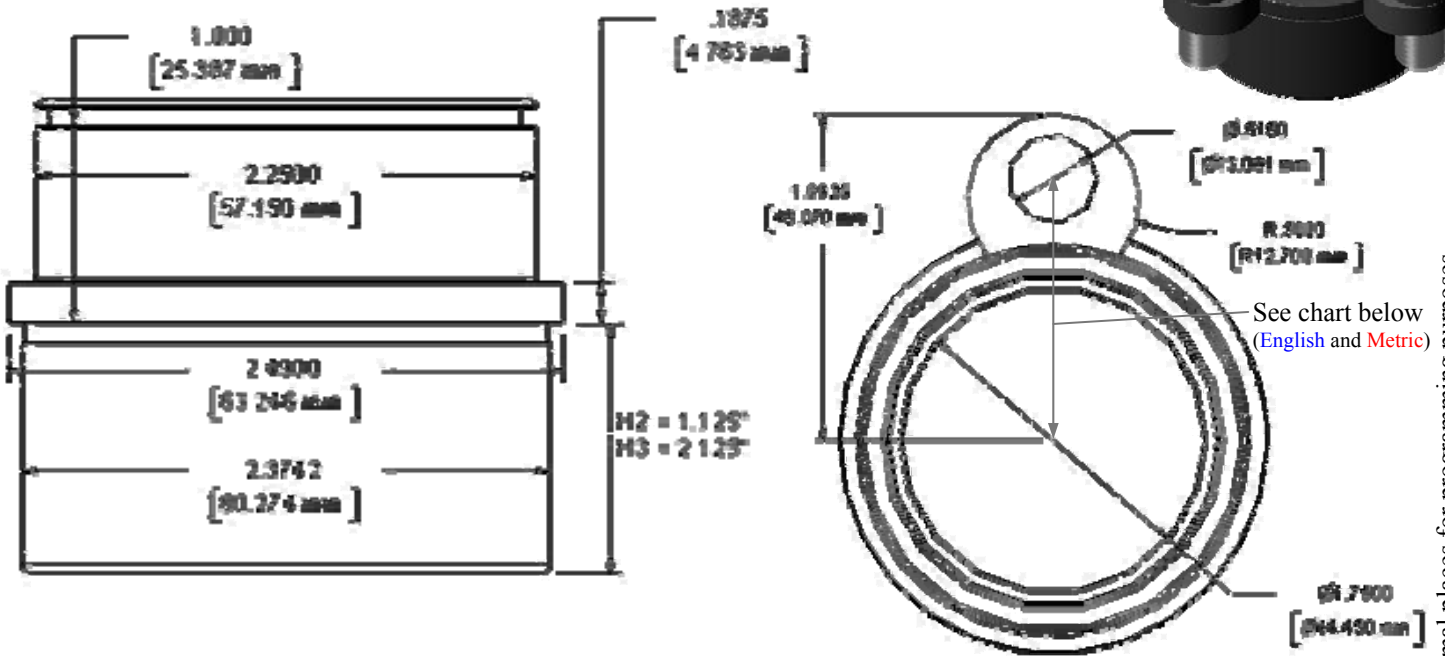

Mounting Specs for	Bore Dia. (-0 +.0010)	Min. Bore Depth	# of Flange Clamps	English Cap Screw Size	Bolt Circle for English	Metric Cap Screw Size	Bolt Circle for Metric
GK175	2.3750	1.2 - 2.2	4	1/2-13	1.510" Rad.	M12-1.75	1.496" Rad.

GK175 Guide Pin Connection Machining

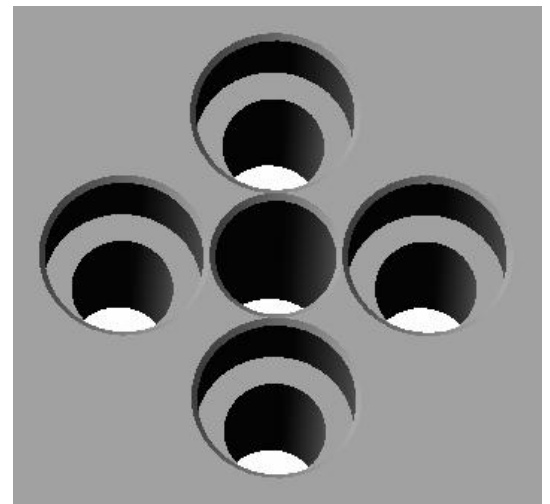
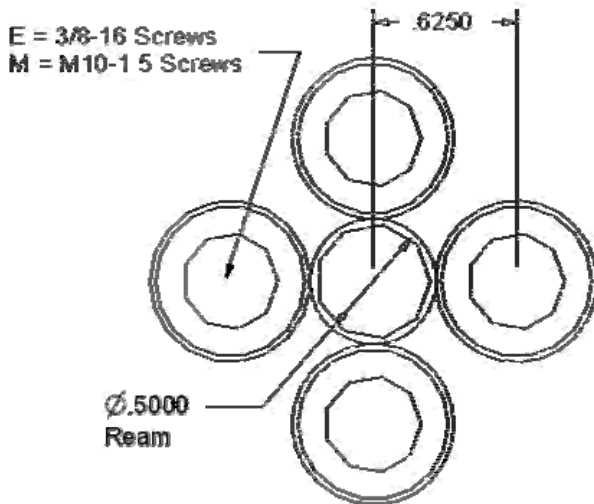

All dimensions shown with 4 decimal places for programming purposes