

# Standard Lifters

MAKING INNOVATION THE STANDARD



Toll Free: 1-877-754-3837 ~ Fax: (616) 301-2182 ~ www.standardlifters.com ~ sales@standardlifters.com

## Guided Keeper Features

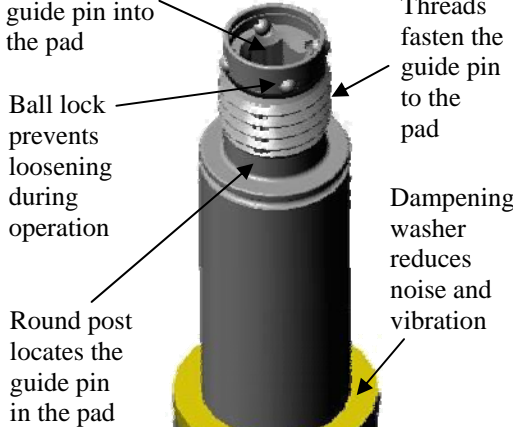
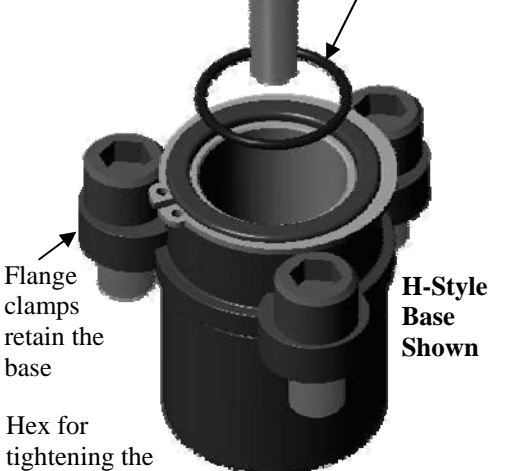
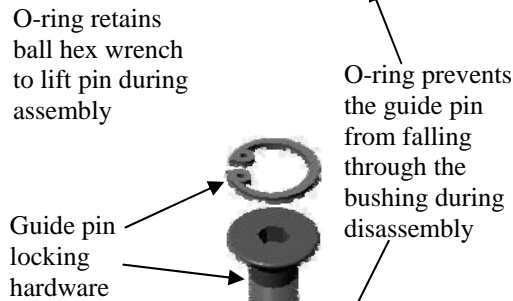
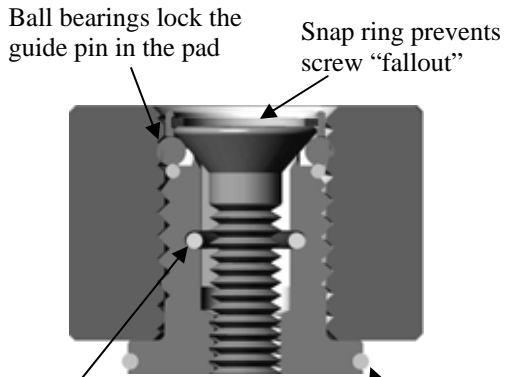

**GK100 Guide Pin**

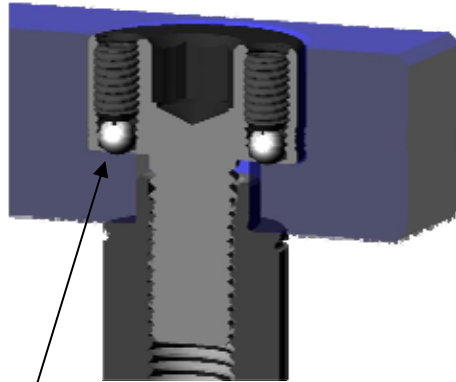

The set screws & bearings in the anti-rotate bolt prevent loosening during operation by sinking into the connecting block

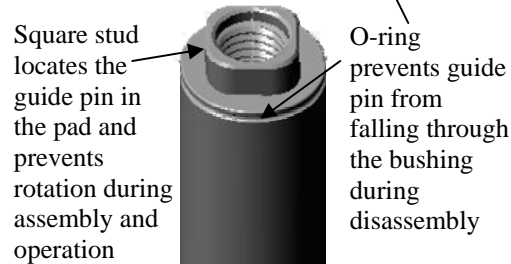
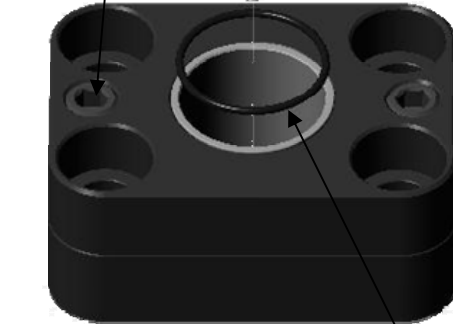
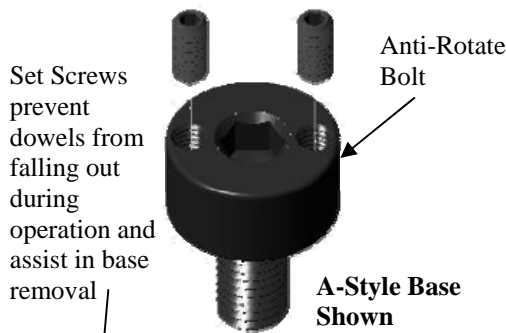

**GK125 Guide Pin**

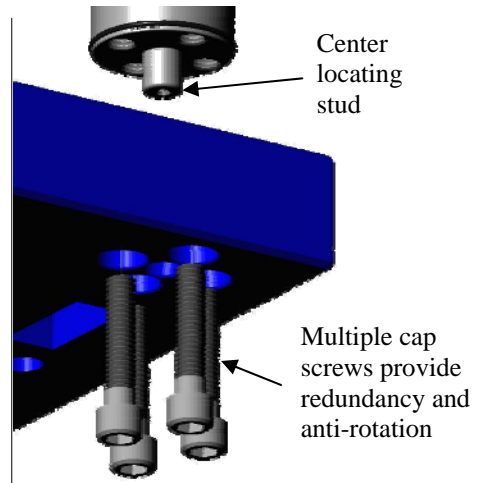

O-ring prevents the Guide Pin from falling through the bushing during disassembly

